

THIS IS A TWO PAGE PARTS LIST.
 THIS SECOND PAGE APPLIES TO
 MODEL No. 20211504 AT REVISION L AND EARLIER REVISIONS

Lubricate seals with clean hydraulic oil prior to assembly.
 DO NOT USE SILICONE BASED LUBRICANTS

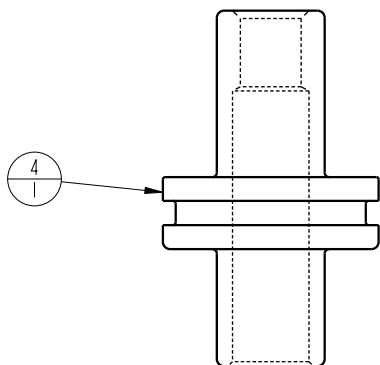

No.	QTY	PART No.	DESCRIPTION
6	1	39VI0022	WIPER,PRESS-IN, (3/4)
5	1	92090001	ASSY, BREATHER, SAE #4
4	1	82011503	PISTON, CYL, HR, 6600
3	1	39011028	SEAL, BEVEL, 1-5/16 X 3/32 X 1-1/2
2	1	39010021	SEAL, LL, (3/4 X 1/8 X 1/8 X 1)
1	1	23314006	SPRING, COMPRESSION

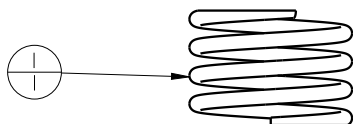
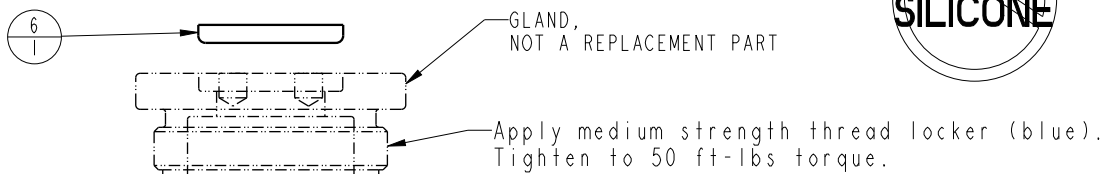
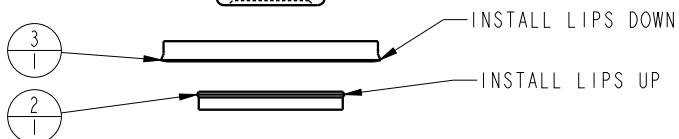

Standard Seal Kit 60-2021-15	Fluorocarbon Seal Kit 6V-2021-15	Spring Kit 61-2021-15
39-0110-28	39-0120-15	23-3140-06
39-0100-21	39-V100-21	
39-V100-22	39-V100-22	

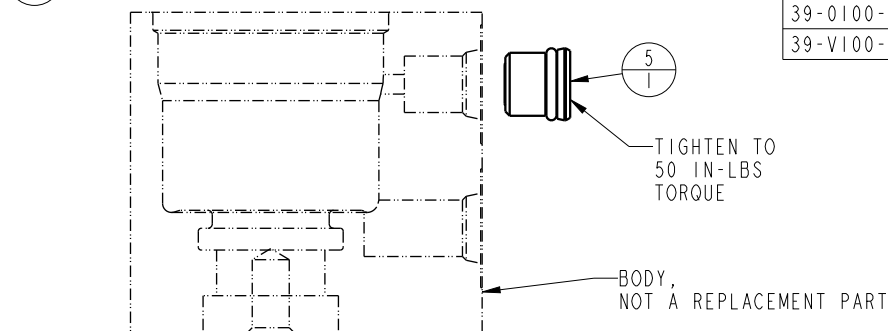

PARTS LIST	 VEKTEK, INC. 1334 E. SIXTH AVE. P.O. BOX 625 EMPORIA, KS. 66801 U.S.A.	
	ASSEMBLIES AFFECTED	PARTS LIST, ASSY, CYL, HR, 6600, SA
20-2115-04		
20-2115-04F	SIZE A	REV M
	PL2030	

M	5486	RELEASE	JDW	08/16/24
REV	IN ACCORDANCE WITH ECN	EFFECTIVE DATE	REVISED BY	DATE
DRW BY: VANDALSEM	DRAWING STATUS: Released			
DATE: 4-7-87	PRODUCTION APPROVED FOR RELEASED STATUS ONLY			

SHEET 2 OF 2